



the
canopyshop

0845 2417182

sales@thecanopyshop.co.uk

www.thecanopyshop.co.uk

Pinnacle Red Tiled Pitched Roof Canopy

The Pinnacle Red Tiled Roof canopy is a freestanding style with solid, opaque, modular polycarbonate tiles covering a pitched shape roof. The rust resistant, grey powdercoated framework is manufactured from aluminium and galvanised steel. The Pinnacle Red Tiled Canopy protects your car from snow, rain, harmful UV rays or leaves shedding and provides an elegant shelter.

- 2 persons' assembly - no high skills are needed
- No unique tools are needed - requires screwdriver, wrenches, drillers and only one ladder
- Ready to assemble - pre-drilled profiles, pre-cut panels, all screws included
- Requires solid surface - no foundations fixing needed
- No roof climbing is needed
- Step-by-step assembly instructions included.



Gutters Included

Ready to assemble - pre-drilled profiles, pre-cut panels, all screws included. No heavy parts - safe easy frame assembly.



Panel Sliding System

No glazing connectors are needed. No Roof climbing is needed - safe & easy fit panels slide on from lower roof end.



Anchoring Kit Included

Requires only solid surface, no foundation fixing needed

- Colour: Grey frame with terracotta coloured, opaque, modular polycarbonate roof tiles.
- Maximum External Dimensions: 338 W x 501 D x 278 H cm
- Internal Dimensions: 300 W x 501 D x 233 H cm
- Poles 80mm x 80mm width, 20 cm height
- Covering Area: 17m² (184 sq ft)
- Snow Loading: Up to 125 kg / m²
- Wind Resistant: Up to 150 kph
- Packaging Dimensions: Box1: 224 x 36 x 17cm, Box2: 224 x 36 x 17cm, Box3:185 x 72 x 5cm
- Product Weight: Box 1: 62 kg, Box 2: 64 kg, Box 3: 22 kg



the
canopyshop

0845 2417182

sales@thecanopyshop.co.uk

www.thecanopyshop.co.uk

Pinnacle Red Tiled Pitched Roof Canopy

Sturdy and Durable - High Performance

- Rust resistant powder coated frame made of aluminium and galvanized steel
- Solid, opaque, modular polycarbonate roof tiles
- Strong poles - 80x80 mm
- Designed laser cut support arms
- Re-assembly option - can be relocated.

Excellent protection

- Wide and high entrance for easy & safe access
- Gutters included - directs rain water sideward and allows water collection
- Protects your vehicles from snow, rain, hail, harmful UV rays and shedding leaves.

Low Maintenance

- No rust, rot, moss or fungus
- Easy cleaning with hose or rain

External Dimensions

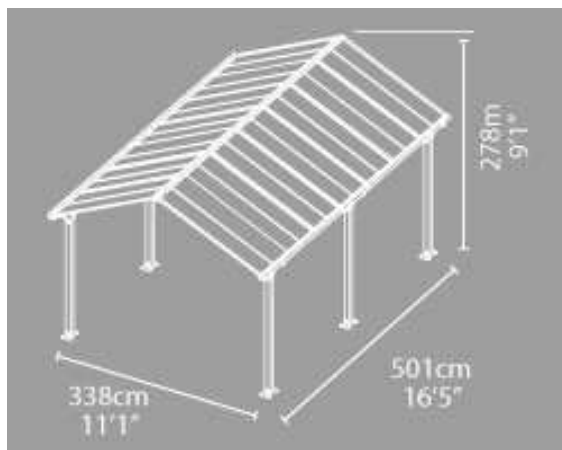

Internal Dimensions

